

## Vibrations, failure of the right main landing gear torsion link during landing roll

<b>Aircraft</b>	Boeing B737-300 registered G-CELD
<b>Date and time</b>	23 July 2011 at 8 h10 UTC <sup>(1)</sup>
<b>Operator</b>	Jet2.com
<b>Place</b>	Paris Charles de Gaulle Airport
<b>Type of flight</b>	Scheduled international transport of passengers
<b>Persons on board</b>	Captain; Co-pilot; 3 cabin crew; 128 passengers
<b>Consequences</b>	Right main landing gear damaged

<sup>(1)</sup>Except where otherwise stated, the times shown in this report are expressed in Universal Time Coordinated (UTC). One hour should be added to obtain the legal time applicable in metropolitan France on the day of the accident.

Note: this document has been translated by the BEA to make its reading easier for English speaking people. As accurate as the translation may be, the original text in French should be considered as the work of reference.

### 1 – HISTORY OF FLIGHT

The following information comes from recorded data and testimony.

On Saturday 23 July 2011 at 8 h 11, the aeroplane was on a stabilised approach to runway 27R Paris Charles de Gaulle Airport (France) on arrival from Leeds/Bradford (United Kingdom).

The aeroplane landed with a ground speed of 129 kt. The crew stated that they felt violent vibrations as soon as the wheels touched down, especially through the rudder pedals. During the landing roll, the recorded lateral load varied with increasing amplitude up to 0.8 g at 90 kt (the lateral load factor then reached the absolute maximum value of 0.41 g) then dropped towards 0.4 g at 80 kt. The aeroplane's path began to deviate slightly to the right of the runway centreline. The oscillations stopped suddenly when the speed reached 75 kt. The aeroplane's lateral deviation in relation to the runway centreline reached a maximum of about 10 m to the right, then the aeroplane moved back onto the centreline.

The aeroplane left the runway via taxiway Z3 and came to a stop before being towed to the ramp. Significant damage was observed on the right main landing gear, especially on the lower torsion link.

### 2 – ADDITIONAL INFORMATION

#### 2.1 Theory of operation of the shimmy damper

The shimmy damper is a hydraulic system installed on each main landing gear. It enables vibrations caused by high landing rollout speed associated with strong braking to be limited. Its main body is attached on to the forward part of the upper torsion link. The actuator rod passes through the forward part of the upper and lower torsion links.

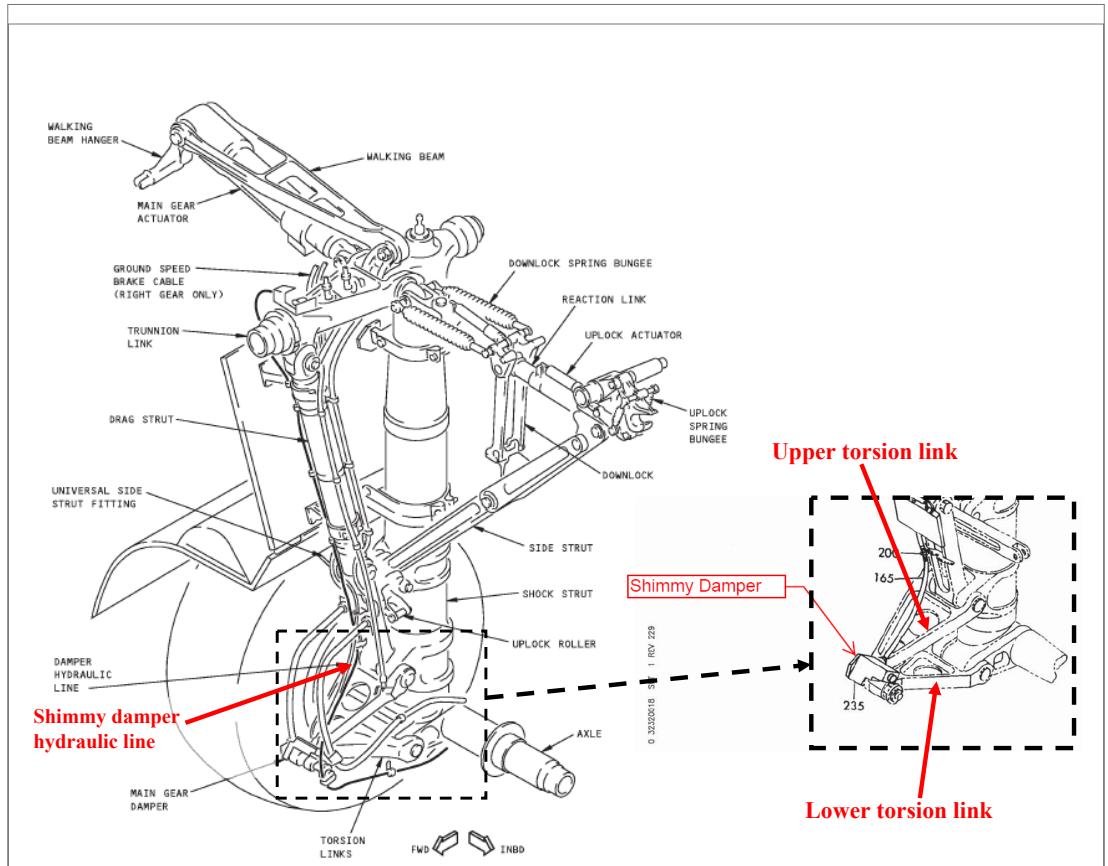

Figure 1 – Overall view of main landing gear

Three check valves enable hydraulic fluid to enter the damper. Rotating oscillation between the inner and outer cylinders of the main landing gear shock strut (see figure 1) is absorbed by the actuator piston. The movement of the actuator acts as a damper in order to counter vibrations. The rate of movement is regulated through a damping orifice.

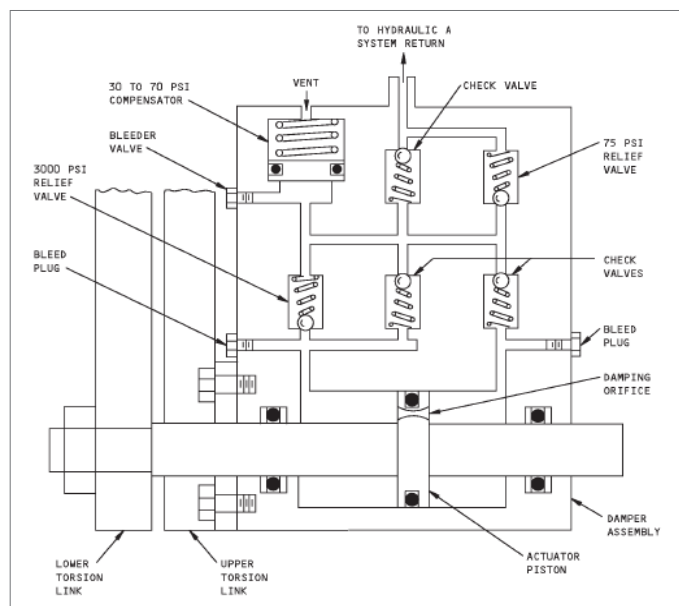

Figure 2 – Schematic of the shimmy damper

A flexible hydraulic line links the shimmy damper to the aeroplane hydraulic system, located in the upper part of the landing gear (see below).

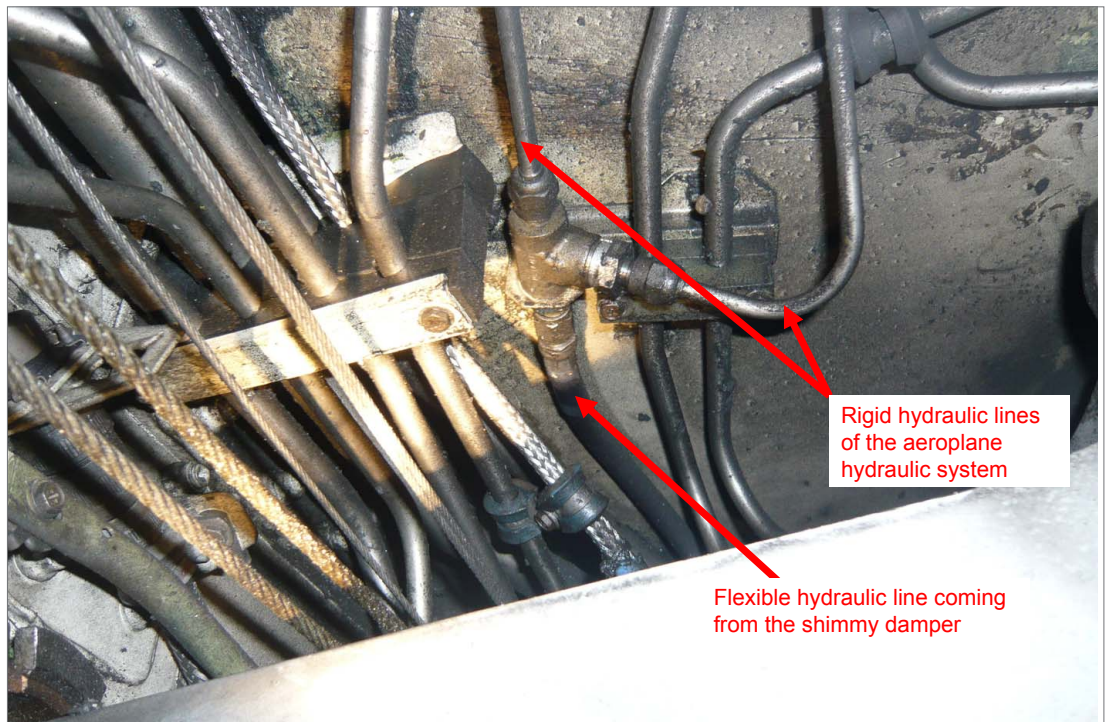

Figure 3 - Installation of lines in normal position

## 2.2 Study on malfunction of anti-shimmy system

On Friday 22 July 2011, the aeroplane underwent maintenance operations that included the complete replacement of the landing gear. These operations took place at the Jet2.com maintenance centre at Leeds/Bradford Airport. During installation of the new right main landing gear, the shimmy damper hydraulic line was not reconnected to the aeroplane's hydraulic system. The following day, the aeroplane took off bound for Paris Charles de Gaulle. This was the first flight after changing the landing gear.

The examinations undertaken after the accident showed that the threaded end that enabled connection of the flexible line to the hydraulic system at the level of the T-junction was blocked by a metal plug similar to that shown in figure 4 below.

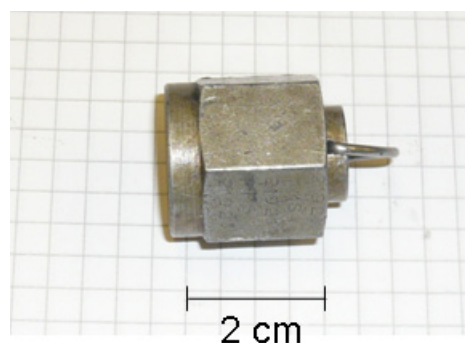

Figure 4 – Metal plug

This plug allows hydraulic pressure to be maintained in the aeroplane's hydraulic system even if the shimmy damper is not connected. The check tests that are performed at the end of the maintenance operation involve extending and retracting the landing gear ten times, with the aeroplane still jacked up. These tests do not engage the shimmy damper and did not make it possible to detect the anomaly.

The shimmy damper was thus not supplied by the aeroplane's hydraulic system. It could not then function normally. During the landing, the vibrations caused by the high speed of the wheels and the heavy braking could not be damped down. The strong vibrations quickly weakened the lower torsion link until it failed suddenly.

### 2.3 Work card

The installation operations on the right main landing gear were undertaken by Jet2.com using work card n°32-011-00-02, called "RIGHT MAIN LANDING GEAR", published by Boeing<sup>(2)</sup>. This card applies to the -300, -400 and -500 versions of the B737 and is based on the Aircraft Maintenance Manual (AMM). It details the operations and procedures that maintenance personnel must apply to the required tasks. This work card is issued by the Jet2.com Planning department and printed before each operation.

This work card contains task n°32-11-00-404-096 "Main Landing Gear Installation", which in itself involves 42 sub-tasks. Each sub-task can include up to a dozen actions. Sub-task n°32-11-00-034-169 corresponds to the reconnection of the hydraulic lines once the landing gear is secured. It applies to all of the lines located in the upper part of the main landing gear, including that of the shimmy damper, but without naming it specifically:

SUBTASK 32-11-00-034-169

(18) Remove the plugs and the caps and connect the upper hydraulic lines.

A task or a sub-task is always carried out by a mechanic and checked by at least one supervisor. They all stamp an endorsement on the work card in the appropriate place. When a task or sub-task is defined as critical, either according to the regulations or by decision of the airline, then a second supervisor also checks the task or sub-task. This is then considered "independently checked". As of 22 July 2011, sub-task n°32-11-00-034-169 was not a task to be independently checked at Jet2.com: one supervisor alone thus stamped an endorsement on the card during the change of landing gear.

When the work card published by Boeing does not completely suit the operator, the latter can add technical notes on the work cards. No note of this type existed about task n°32-11-00-404-096 on 22 July 2011.

Airlines using Boeing work cards can inform the latter of any clarifications or modifications that seem to them to be necessary. Boeing stated that they had not received any comments relating to the sub-task concerning the reconnection of the shimmy damper hydraulic line.

<sup>(2)</sup>There is also a work card for changing the left main landing gear (n°32-011-00-01).

## 2.4 Workload and time pressure

On 22 July 2011, the Jet2.com maintenance teams were staffed to handle two aeroplanes: G-CELD as well as another aeroplane that was subject to routine inspections. When a third aeroplane arrived for an unplanned repair to its fuselage, the workload exceeded the capacities of the personnel.

Thus, the supervisor interrupted his work in order to deal with an issue that arose on one of the two other aeroplanes. The mechanics were also redirected from one aeroplane to another, without any coordination between them being set up in accordance with the existing procedures. This led to errors and approximations. Specifically, the reconnection of the shimmy damper to the hydraulic system on G-CELD was omitted, even though the mechanic's and the supervisor's endorsements for the corresponding task were stamped on the work card.

An internal Jet2.com investigation report stated that the supervisor working on G-CELD had already accumulated an excessive number of working hours, causing fatigue and affecting his performance. Significant time pressure built up, while trying to deal with three aeroplanes at the same time by using the same resources as those required for two aeroplanes.

## 3 – LESSONS LEARNED AND CONCLUSION

### 3.1 Corrective actions taken by Jet2.com

Within the framework of flight safety and quality assurance, Jet2.com carried out an investigation following this accident. The following measures were recommended in order to improve workload management and specifically ensure the reconnection of the hydraulic lines. They have been in force since September 2011.

- A new technical procedure was published relating to managing and checking plugs to blank off hydraulic systems, as well as pneumatic and gas systems. This specified the attachment of identification tags visibly on the plugs used and making an entry in a log every time a plug is placed on a pipe or line. As soon as a plug is removed, a new entry in the log is to be made. At the end of the operation, the procedure requires a check that the number of plugs placed should be the same as the number of plugs removed.
- Jet2.com added some items on the landing gear change work card that specifically require checking the hydraulic connection on the shimmy damper and an independent check being made by a 2nd supervisor.
- A new work schedule system was implemented so as to better manage fatigue. This imposes a four-days-on/ four-days off shift system. It also limits to 48 hours the number of hours worked over a 7-day period. This limit can be extended to 60 hours in case of unexpected work constraints.
- The planning of maintenance tasks was re-evaluated and adjusted in order to avoid overloading available resources.
- Feedback on this event was integrated into the maintenance personnel training programme.



### 3.2 Corrective actions taken by Boeing

Maintenance operations to replace the main landing gear on B737 -300, -400, and -500 are described in work cards, these being based on documentation supplied by Boeing. In July 2011, at the time the landing gear was changed at Jet2.com, this documentation indicated in a general manner the need to reconnect the hydraulic lines, though without specifically mentioning the main landing gear shimmy damper hydraulic line.

In November 2011, Boeing published temporary revisions to the B737-300, -400 and -500 AMM related to the removal/installation of the shimmy damper<sup>(3)</sup> and the removal/installation of the main landing gear<sup>(4)</sup>. They now specifically require reconnection of the main landing gear shimmy damper hydraulic line, as well as a purge thereof. These temporary revisions are scheduled to be incorporated in the 25 March 2012 version of the AMM, which will also update the associated work cards.

<sup>(3)</sup>Temporary  
Revision  
n°32-1015.

<sup>(4)</sup>Temporary  
Revision  
n°32-1016.

### 3.3 Conclusion

The accident was caused by the failure, undetected by the maintenance personnel, to reconnect the right main landing gear shimmy damper hydraulic line to the aeroplane's hydraulic system. The vibrations caused during landing rollout could not be damped down and weakened the torsion link until it failed suddenly.

The following factors contributed to the accident:

- Poor resource planning caused overstretching of the personnel's capacities when unexpected extra work turned up. This generated increased time pressure that led to things being forgotten and approximate execution of the work cards.
- The supervisor had worked for an excessive number of hours over a long period of time, which lowered his performance and his aptitude to carry out checks efficiently.
- Boeing work card n°32-011-00-02 in force in July 2011 did not specifically mention re-connecting the shimmy damper hydraulic line to the aeroplane's hydraulic system.