

Elevator trim system cable failure on initial climb, flight aborted

Aircraft	Beechcraft 1900D registered F-GOPE
Date and time	9 October 2012 at about 07 h 40 ⁽¹⁾
Operator	Hex'air
Place	Lyon Saint Exupéry (69) airport
Type of flight	Public transport, scheduled domestic passenger service
Persons on board	Captain (PM); copilot (PF); six passengers
Consequences and damage	None

⁽¹⁾Unless otherwise specified, the times given in this report are expressed in local time/ in coordinated universal time (UTC).

This is a courtesy translation by the BEA of the Final Report on the Safety Investigation. As accurate as the translation may be, the original text in French is the work of reference.

1 - HISTORY OF FLIGHT

The crew was making a flight between Lyon Saint Exupéry airport and Rodez Marcillac airport. The conditions were VMC. On initial climb, the PF noted that his input on the elevator trim electrical control had no effect. The trim's manual control did not function either. The PF stabilised the aeroplane at an altitude of 5,000 ft and a speed of 140 kt. The crew decided to turn back and maintained a speed of less than 140 kt until final.

The crew landed on runway 36L in 35° flap configuration.

On the ground, the cable of the elevator trim was found fractured.

2 - ADDITIONAL INFORMATION

2.1 The Crew

The captain totalled 10,000 flying hours including 9,400 on type, 100 hours in the previous three months and three hours in the previous 24 hours, all on type.

The copilot totalled 1,000 flying hours including 500 on type, 120 hours in the previous three months and two in the previous 24 hours, all on type.

2.2 Description of the Elevator Trim System and Related Procedures

The Beech 1900 elevator trim system has a steel cable, forming a loop, between the cockpit and the elevator.

It consists of seven strands, each consisting of seven wires. It is controlled:

- Electrically using a control located on the control stick;
- Manually using a wheel positioned either side of the centre console.

This trim system is dependent on the aeroplane autopilot. In the event of the electric trim not operating, a "PITCH TRIM" warning is displayed on the instrument panel. The pilot can then use the trim manually.

Before start-up, the check-list requires the trim electric control switch to be in the ON position. Before taxiing, the functioning of the trim override is checked and then a check of its disconnection with verification of the "PITCH TRIM" display light is carried out.

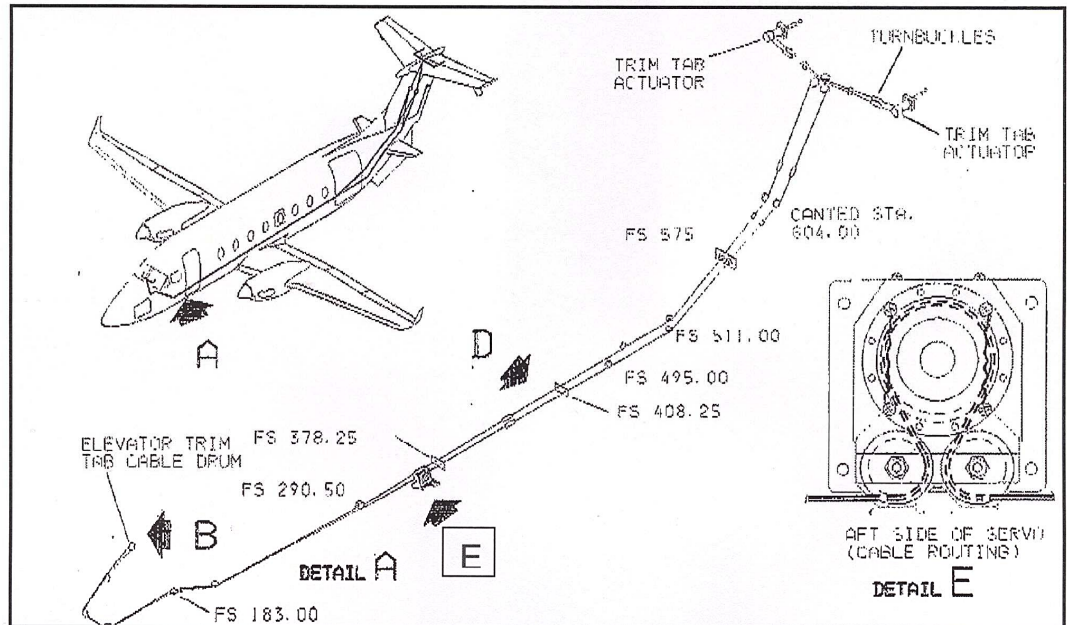

Diagram of Trim System

2.3 Examination of the Elevator Trim Cable

F-GOPE elevator trim cable was found fractured at the winding level around the pulleys of the autopilot servo-control (see diagram above). Half of the wires fractured through overload and the other half through fatigue crack propagation.

This fatigue fracture seemed to be related to the specific stresses of the cable when being wound round the pulley (see detail E of the diagram in paragraph 2.2)

The material and its surface treatment complied with the manufacturer's specifications.

After the F-GOPE incident, the elevator trim cable of an aeroplane of the same type and from the same airline (F-GUPE, 16,632 cycles with 14,658 flying hours) was examined during scheduled maintenance.

Examination of the F-GUPE cable using a scanning electron microscope highlighted incipient damage undetected by visual inspection alone. Only meticulous radiographic examination, requiring the disassembling of the cable, then made it possible to detect the presence of fractured wires within the strands to be detected. All the wires of the central strand and three wires on the peripheral strands in the first cable sample (roughly 20% of all the wires making up the cable) were fractured. Four wires of the central strand and 4 other peripheral wires in a second sample (which represents 16% of all the wires) were fractured.

2.4 Aeroplane maintenance

The visual inspections carried out during the scheduled maintenance checks for both these aeroplanes, including the use of a rag to detect the fractured wires, did not make it possible for any damage to be detected on the elevator trim cable.

F-GOPE had totalled 21,144 cycles and 15,400 flying hours. It was up to date with maintenance operations. During these checks, the autopilot servo-controls had been checked visually. During the first and third 200-hour checks, the cable, tension and transmission were checked. During the sixth 200-hour check, the cable tension was checked again, without any anomaly being detected. The systematic or regular replacement of the elevator trim cable is not provided for on this type of aeroplane and only occurs when damage is noted.

2.5 Similar Cases

In September 2006, a fracture of an elevator trim cable had been reported by an operator. The manufacturer issued a Safety Bulletin⁽²⁾ recommending the annual inspection of the cable at its winding point in the elevator servo-control. It was specified that the elevator must be fully unwound and any abnormal sounds, jolts and fittings must be noted. Inspection is also visual.

The Safety Bulletin states: *“Technical inspection of the flight control cables and the criteria are contained in the Beech 1900D AMM, chapter 20-04-00, CONTROL CABLE SYSTEM INSPECTION. The cable must be inspected to detect any incorrect unwinding, unravelling or fractured wires. In accordance with the criteria defined in the Beech 1900D AMM, any worn or damaged cable must be replaced.”*

3 - LESSONS LEARNED AND CONCLUSION

3.1 Maintenance of elevator trim cables

The fatigue fractures observed on the F-GOPE elevator trim cable, and the first wire fractures noticed on the F-GUPE elevator trim cable, demonstrate that the elevator control cable was subject to damage that was difficult to detect, if at all, with the planned maintenance operations.

The maintenance programme only provides for the replacement of the cable in the event of premature wear being detected visually during these inspections, or with the aid of a rag.

Following the 2006 safety bulletin, the manufacturer neither modified scheduled maintenance actions on the cable nor set specific checks or expiry limits on the cable.

3.2 Causes

The incident was due to wear by fatigue cracking of steel wires making up the strands of the elevator trim cable, which could not be detected during scheduled maintenance.

4 - SAFETY RECOMMENDATION

Note: In accordance with Article 17.3 of Regulation N° 996/2010 of the European Parliament and Council of 20 October 2010 on the investigation and prevention of civil aviation accidents and incidents, a safety recommendation shall in no case create a presumption of blame or liability for an accident, serious incident or incident. Recipients of safety recommendations shall inform the safety investigation authority which issued the recommendations of the actions taken or under consideration to ensure their implementation, as provided by Article 18 of the aforementioned Regulation.

Modification of the elevator trim system

The investigation showed that the steel wires that make up the elevator trim cable were subject to fatigue fracture that was undetectable with the inspections provided for during aeroplane maintenance. A similar event had generated a Safety Bulletin from the manufacturer in October 2006. The latter only recommended a visual and mechanical check of the cable.

Consequently the BEA recommends that:

- **FAA, in coordination with the manufacturer, make mandatory a modification of the elevator trim system or, failing that, the replacement of the elevator trim cable at regular intervals, in order to avoid undetectable fatigue fracture of the cable. [Recommendation 2015-013]**